

Diesel Exhaust Fluid

KB1060 Series Commercial Dispensers

Installation & Operation Manual



Model SBD KB1062
(Combination model SBD KB2070)



Model SBD KB1062-HR, Combination
model: SBD KB2070-HR)



Model
SBD KB1060-HR
shown w/stand.

Meets ISO 22241
and PEI RP1100

© 2017 KleerBlue Solutions. All rights reserved. No part of this document can be photocopied, reproduced, stored in a retrieval system, or transmitted in any form or any means, whether electronic, mechanical, or otherwise, without the prior written permission of KleerBlue Solutions.

KleerBlue Solutions reserves the right to change details in this publication without notice.

Sotera® and Sotera® Systems are registered trademarks of Tuthill Transfer Systems, Tuthill Corporation.

Piusi® is a registered trademark of Pompe Piusi S.R.L. Corporation, Italy.

OPW® is a registered trademenk of Delaware Capital Formation, Inc., Wilmington, DE

Husky® is a registered trademark of the Husky Corporation, Pacific, MO

Table of Contents

1. Safety Warnings.....	3
2. DEF Caution Statement	3
3. Receipt and Inspection.....	3
4. General Description	4
5. Standard Specifications.....	4
6. Dimensions	5
7. Mechanical Installation Instructions	6
8. Electrical Installation Instructions	7
9. Electrical Installation Instructions by Model #.....	9
• Models SBD KB1060 & KB1060HR	9
• Models SBD KB1062 & KB1062HR	10
• Models SBD KB1060PO & KB1060POHR.....	11
• Models SBD KB1062PO & KB1062POHR	13
10. System Startup Instructions	15
11. Operating Instructions (by Model #).....	15
• Models SBD KB1060 & KB1062	16
• Models SBD KB1060PO & KB1062PO	17
• Models SBD KB1060HR & KB1062HR	18
• Models SBD KB1060POHR & KB1062POHR	19
12. Parts List	20
13. Trouble Shooting Guide.....	21
14. Maintenance and Repair	22
Warranty	23
Installation Checklist	(Inside back cover)

! WARNING



TURN POWER OFF

Before performing any maintenance, be sure to turn system power off, and place “Lock-Out, Tag-Out” protection in place to avoid electric shock.



EYE PROTECTION

Pressurized systems may cause leaks and spray that may be dangerous for your eyes. Always wear eye protection.



INJURY

Wear gloves for protection from liquids that may cause irritation or burns.



READ

Read and understand all related manuals thoroughly.

CAUTION: Keep your DEF Pure!

DEF is WATER based and must be kept PURE and UN-CONTAMINATED

Use only compatible wetted materials for storing and dispensing DEF. Compatible materials include:

- 300 series Stainless Steel
- Polypropylene and Polyethylene
- EPDM and Viton gaskets and seals
- Special, approved hose.

DO NOT USE: Cast Iron, black iron, carbon steel, plated steel, aluminum, plated aluminum, copper, brass, bronze, zinc, lead, magnesium, silver, PVC for CPVC. See ISO 22241 and PEI RP1100 for additional information.

Receipt, Inspection & Identification

Upon receipt of the Klear-Blue™ Dispenser, inspect for damage and sign delivery receipt only if no damage is present. Promptly notify delivery company about any damage.

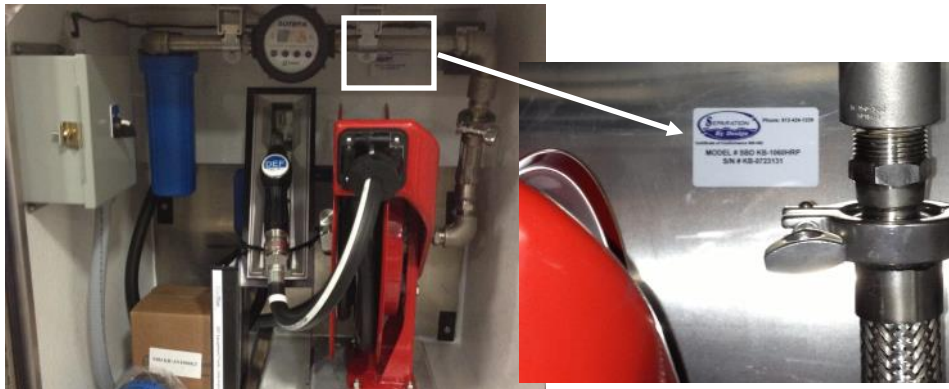

Each unit is identified with a Serial Number Plate as shown in photo.

General Description

SBD KB1060 & 1062 Commercial DEF Dispensers are specially designed to dispense DEF into DEF tanks on vehicles with diesel powered engines that are fitted with Selective Catalytic Reduction (SCR) pollution control systems.

- SBD KB1060 Commercial DEF Dispensers are sold as stand alone dispensers to be used with above- or below-ground tanks and pumping systems.
- SBD KB1062 Commercial DEF Dispensers are attached to KleerBlue™ 400 gallon or 1,000 gallon Mini-bulk tanks. Tank & Dispenser Combination models include:
 - ⇒ SBD KB2060 = 400 gal tank with a KB1062 attached
 - ⇒ SBD KB2070 = 1,000 gal tank with a KB1062 attached
- “PO” Suffix attached to any model # designates addition of a ‘pulse-out’ meter.
- “HR” Suffix attached to any model # designates addition of a 25 ft hose reel. NOTE: This option requires use of a larger aluminum (28-inch versus 10-inch depth).

Specifications

STANDARD:

- **Dimensions:** (see “Dimensions” section)
- **Enclosure:** Industrial grade aluminum cabinet, insulated and heated.
- **Power Requirements:** 120VAC. See “Electrical Installation Instructions” section in this manual for specific model number power requirements.
- **Flow rate:** Adjustable with inlet valve. Recommended 8-10 gpm with automatic nozzle
- **Inlet** = 3/4” hose barb
- **Outlet** = outlet hose end is determined by nozzle size: 3/4-inch male NPT, or 1-inch female BSPP (for OPW nozzles).
- **Hose Length:** 12 ft.
- **Meter:**
 - ⇒ SBD KB1060 & KB1062: Sotera® Polypropylene Meter w/ LCD Display
 - ⇒ SBD KB1060-PO & KB1062-PO: Piusi® Pulse-out Meter w/ LCD Display
- **Display Units:** Gallons or Liters, selectable.
- **Heater:** 400W, 120 VAC, forced air
- **Filter:** Heavy-duty poly construction, 10” long, 1-micron, ultra-efficient, replaceable element.

OPTIONAL:

- **Hose Reel (HR Option):** with 25-ft. hose (requires 28” deep cabinet)
- **Cabinet Dispenser Stand:**
 - ⇒ For Model SBD KB1060 = Part# SBD 1060FS10D
 - ⇒ For Model SBD KB1060-HR = Part# SBD 1060FS28D
 - ⇒ For Model SBD KB1062-HR (tank mounted model) =Part# SBD 1062FS28D
- **Nozzles and Accessories:**
 - ⇒ SBD NOZ-3/4N: Stainless Steel Automatic nozzle, 3/4” NPT.
 - ⇒ SBD NOZ-75B: Stainless Steel swivel-breakaway, N 3/4” NPT.
 - ⇒ SBD SSNOZ-7545: Stainless Steel 45° swivel fitting, 3/4” NPT.
 - ⇒ SBD OPWSSNOZZL: OPW 21GU-0500 NOMA with Mis-filling Prevention, 1” BSPP.
 - ⇒ SBD OPWSTDNOZ: OPW 21GU-0400 NOMA without Mis-filling Prevention, 1” BSPP.
 - ⇒ SBD 21GU-SSB: Replacement swivel breakaway for the OPW nozzle
 - ⇒ SBD OPWMFPD: Magnet that activates the Mis-filling Prevention.
- **No Heat**

Dimensions: KleeBlue™ Commercial Dispensers

NOTE: All dimensions are in inches. For fully assembled weights, please contact factory.

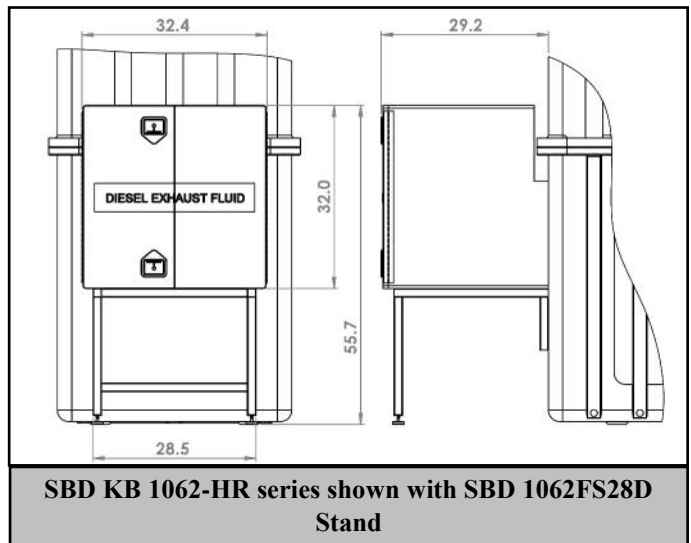
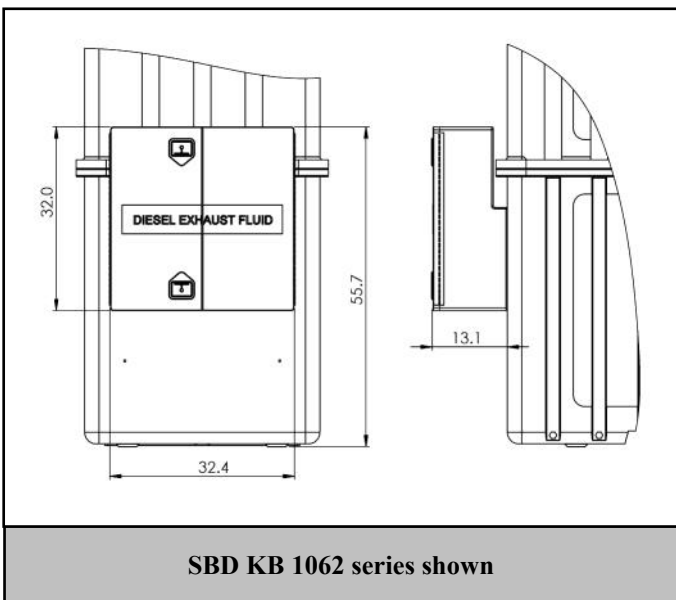
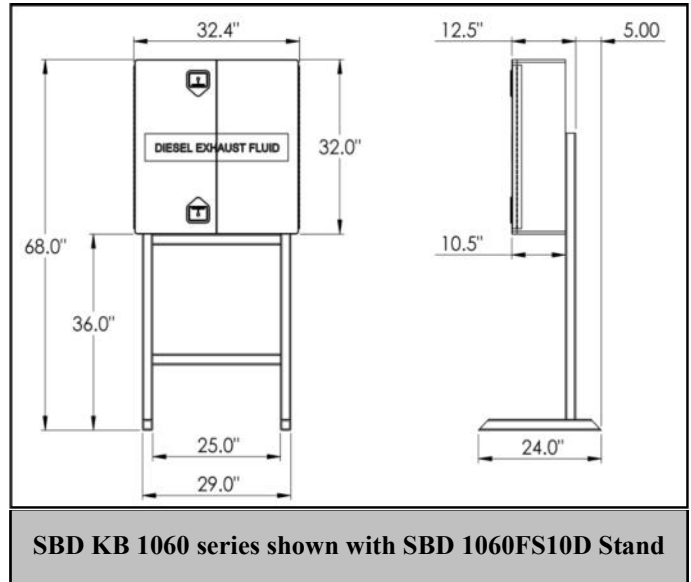
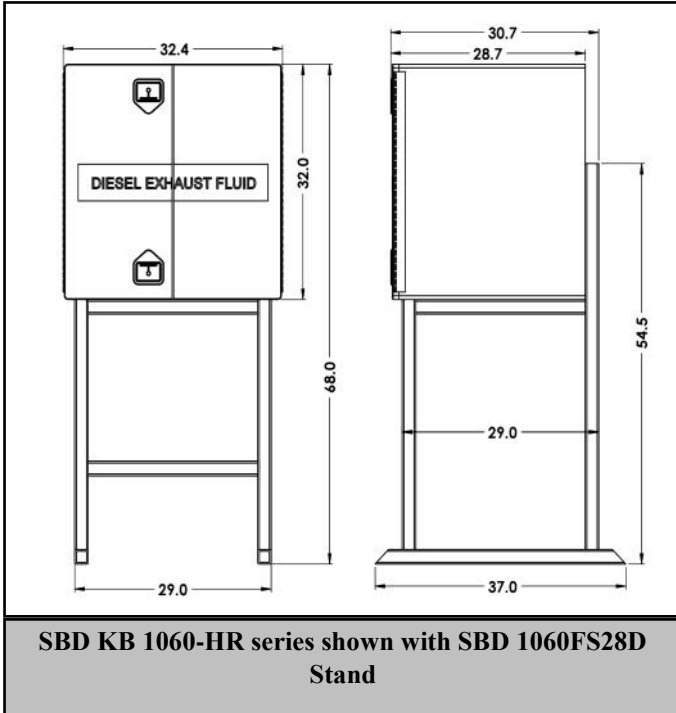

Mechanical Installation Instructions

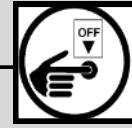

WARNING

ELECTRICAL HAZARD

SERIOUS INJURY OR DEATH MAY RESULT FROM ELECTRICAL SHOCK.
ONLY CERTIFIED ELECTRICAL CONTRACTORS SHOULD INSTALL SYSTEM.

SBD KB1062 & KB1062-HR Commercial Dispensers come factory-installed to a 400 or 1,000 gal KB Mini-bulk tank (the combined units are identified as Models **KB2060** or **KB2060-HR** and **KB2070** or **KB2070-HR** respectively).

- All plumbing for these units is done at the factory.
- **KB1062-HR** includes stand # **SBD 1062FS28D**, which has adjustable feet for leveling on uneven ground (see Fig.1).
- Once tank is anchored to the ground, no additional mechanical installation is needed.



Fig 1: SBD 1062FS28D Stand showing leveling feet.



Fig 2: Fluid Inlet options: side or bottom

SBD KB1060 & KB1060-HR

- The **KB1060** flat-backed dispensers can be mounted to a sturdy wall using the back panel mounting slots, or mounted to a sturdy stand (such as # **SBD 1060FS10D** or **SBD 1060FS28D**, see page 5). Stands should be anchored to concrete to prevent accidental movement (see section under “General Instructions for Anchor Installation” for detailed instructions).
- The fluid inlet to the KB 1060 is a 3/4-inch Hose barb (see figure 3). Fluid must be connected from the tank pump to the dispenser. The recommended method is as follows:
 - a. Use the **SBD 910692** mounting kit, which includes a stainless 1” bulkhead fitting (see Fig 4), a hose barb adapter, 3 feet of 3/4” DEF hose, and hose clamps.
 - b. Punch or drill (with a hole saw) a 1 & 11/16-inch hole in a convenient location to mount 1-inch stainless bulk head fitting (see Figs 2 and 4).
 - c. Install reducing hose barb in the stainless bulkhead fitting before inserting into cabinet. Install incoming plumbing to the bulk head fitting.
 - d. Cut the hose to length and install on both hose barbs with hose clamps. Tighten hose clamps well.

Figure 3: Inlet valve and hose barb.



Outside of Cabinet Inside of Cabinet



Figure 4: Stainless bulkhead assembly. See Figure 2 above for recommended inlet connection location.

- **All plumbing outside of the dispenser must be heated and insulated in cold climates.**

Mechanical Installation Instructions (cont'd)

General Instructions for Anchor Installation

- 1) Put a mark on the concrete where the hole for the anchor needs to be drilled.
- 2) Use a hammer drill with a carbide tipped masonry bit to drill a 3/8" hole 2.5" - 2.75" deep.
- 3) Clear the holes of debris using compressed air, a vacuum, or a wire brush.
- 4) Before inserting the wedge anchor into the hole, place the washer on, then thread the nut on a couple of turns. Not fully threading the nut protects the threads of the wedge anchor.
- 5) Insert the wedge anchors into each hole of the fixture.
- 6) Carefully hammer the anchors into each hole ensuring that they are installed to the desired depth.
- 7) Tighten the anchor nuts using a torque wrench to ensure they are tightened to 25-30 ft*lbs.

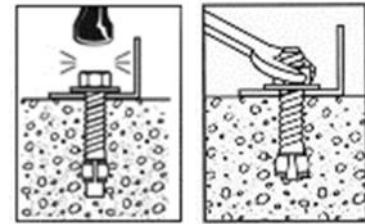
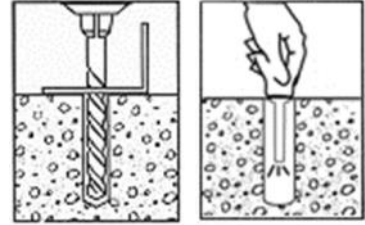

Visit www.wedge-type-anchor.com to view a video of the proper way to install the wedge anchors. Also visit www.itwredhead.com for more information.

Electrical Installation Instructions



WARNING

ELECTRICAL HAZARD

SERIOUS INJURY OR DEATH MAY RESULT FROM ELECTRICAL SHOCK.
ONLY CERTIFIED ELECTRICAL CONTRACTORS SHOULD INSTALL SYSTEM.

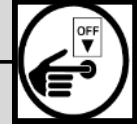

General Instructions (ALL MODELS)

- Use only 75C-rated copper conductors for cabinet.
- Select proper wire size according to NEC and all applicable local codes and standards.
- All incoming power wires **MUST** be protected in conduit and all entries into the junction box or dispenser must be sealed with weatherproof conduit fittings.
- To prevent hand contact as well as damage to wires from hose reel rotation, all wires inside cabinet **MUST** be protected in conduit.
- Protect system components in the dispenser cabinet from metal chips and other debris when drilling conduit openings. Failure to do so may damage or destroy dispenser equipment.
- Seal all punched or drilled cabinet openings after completing installation.

Electrical Installation Instructions (Cont'd)

NOTE: Unless otherwise noted in this manual, all instructions assume installation and use of a single dispenser per site. For installations where multiple dispensers are being used at one site, see special note at the end of this section.

- 1) The DEF pump, located at the DEF tank, is controlled by the KB1060 series dispenser via the ON/OFF switch located at the junction box.
- 2) Assuming that a single KB1060 series Dispenser is being utilized, power for the DEF pump should enter the KB1060 Dispenser junction box and then be routed to the pump.

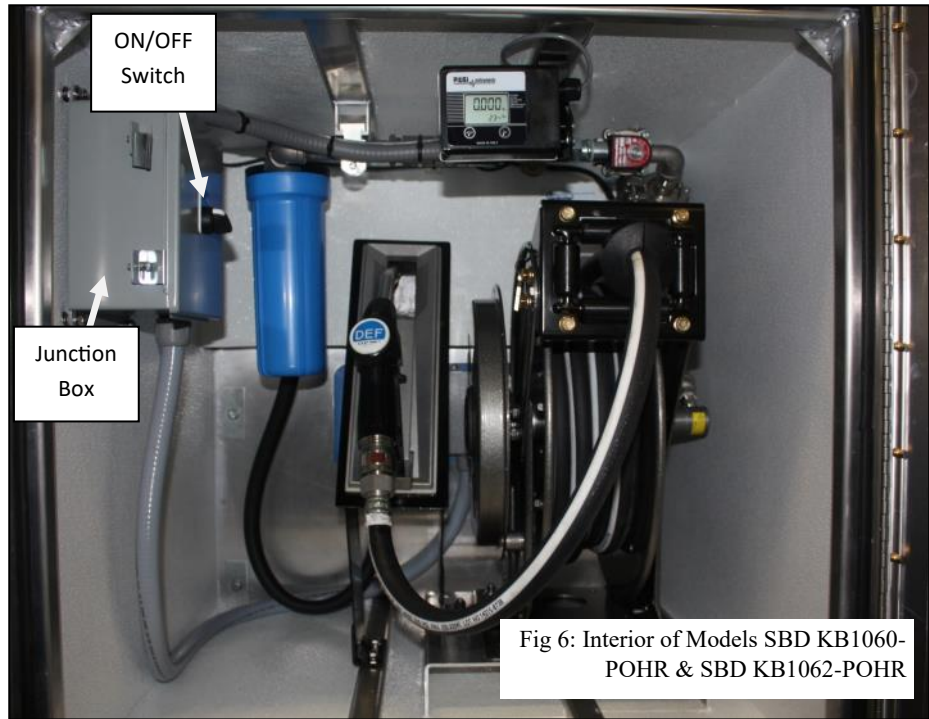

- 3) Continue with installation according to instructions for your specific dispenser model number on the following pages.

Section	A	MODEL SBD KB1060 & KB1060HR	9
Section	B	MODEL SBD KB1062 & KB1062HR	10
		(Mounted to Mini-bulk Tank)	
Section	C	MODEL SBD KB1060PO & KB1060POHR	11
Section	D	MODEL SBD KB1062PO & KB1062POHR	13
		(Mounted to Mini-bulk Tank)	

Model Specific Electrical Installation Instructions

Mini-bulk Tank Mounted Model

B SBD KB1062 & KB1062HR

with *Sotera™* Meter

- 1) KlearBlue™ requires two circuits to power these dispenser models:
 - One 120 VAC, 20 amp circuit to power the pump
 - One 120VAC, 20 amp circuit to power the dispenser heat, tank heaters, and the tank monitor (if present)
- 2) For the 120VAC, 20 amp pump circuit, connect the incoming pump circuit power wires as follows (see figures B3):
 - Terminal 9 (Pump 120VAC Line Voltage)
 - Terminal 13 (Pump Neutral)
 - GND (Ground)
- 3) The second 120VAC, 20 amp circuit will power the heaters in the commercial dispenser and tank, as well as the tank monitor at the fill end of tank (if present). Connect the incoming Heat power wires as follows (see figures B3):
 - Terminal 1 (Tank & Dispenser Heater 120VAC Line Voltage)
 - Terminal 2 (Tank & Dispenser Heater Neutral)
 - GRD (Ground)
- 4) Terminal 12 is used if a “Motor Running Indicator” is needed. This is not common for these models.
- 5) All internal connections to the pump, heaters, and tank monitor are pre-made at the factory. No additional wiring necessary.
- 6) There is a timer that will allow the pump to run for up to 10 minutes. It is adjustable, and resets after the switch is switched to “Off”.

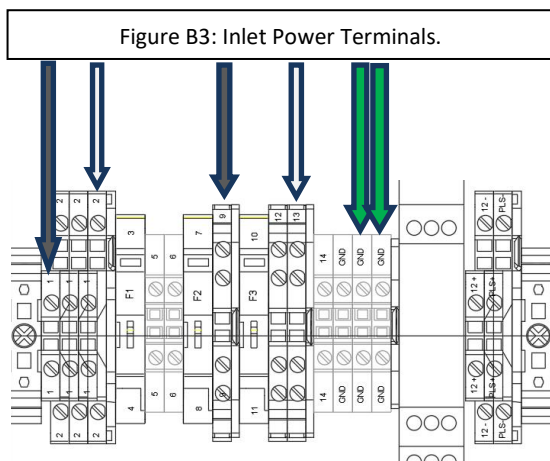
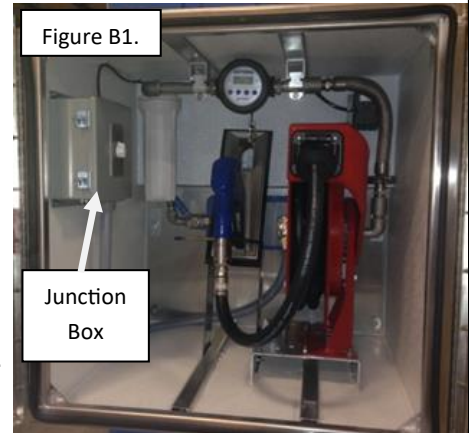

GO TO PAGE 14 OF THIS MANUAL

Model Specific Electrical Installation Instructions

Model



SBD KB1060PO & KB1060POHR

with *Piuser*™ Pulse-out Meter

KleerBlue™ recommends two circuits to power these dispenser models:

- ⇒ One 120 VAC, 20 amp circuit to power the pump.
 - ⇒ One 120VAC, 15 amp circuit to power the dispenser heat.
 - ⇒ In addition, a 12VDC circuit is required from the Remote Fuel Management (RFM) system (if used). See item number 7 on following page.
- 1) The 120VAC, 20 amp pump circuit should come from the RFM system to authorize the dispenser.
 - If the RFM system does not have a 20 amp pump relay, you must purchase a Switch Box (SBD SWBOX-1D) to put between the dispenser and the RFM system. The 120VAC 20 amp power circuit then enters the SWBOX-1D, and is sent to the dispenser when authorized by the RFM.
 - 2) Connect the incoming pump circuit power wires as follows (see Fig. C3, next page):
 - Terminal 9 (Pump 120VAC Line Voltage)
 - Terminal 13 (Pump Neutral)
 - GND (Ground)
 - 3) The second 120VAC, 20 amp circuit will power the heaters in the commercial dispenser. Connect the incoming Heat power wires as follows (see Fig. C3, next page):
 - Terminal 1 (Tank & Dispenser Heater 120VAC Line Voltage)
 - Terminal 2 (Tank & Dispenser Heater Neutral)
 - GRD (Ground)
 - 4) The power out to the pump comes from (see Fig. C4):
 - Terminal 12 (pump power out, 120VAC Line Voltage)
 - Terminal 13 (pump power out Neutral)
 - GND (ground)
 - 5) Terminal 12 is used if a “Motor Running Indicator” is needed.
 - 6) There is a timer that will allow the pump to run for up to 10 minutes. It is adjustable, and resets after the switch is switched to “Off”.

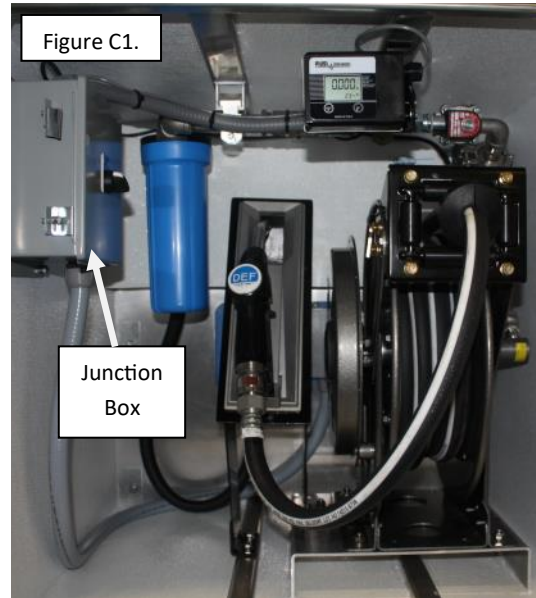

CONTINUED ON NEXT PAGE...

Model Specific Electrical Installation Instructions (cont'd)

Model



SBD KB1060PO & 1060POHR

with *Piusi™ Pulse-out Meter*

Figure C3: Inlet Power Terminals.

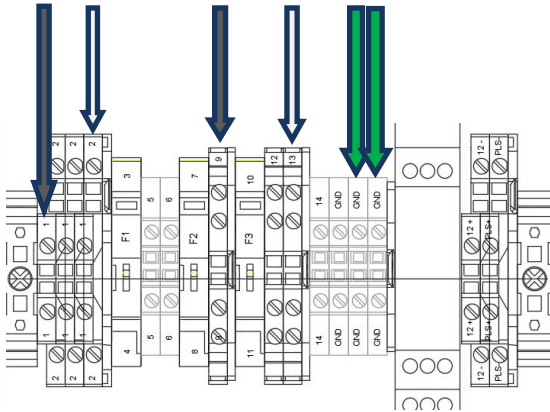
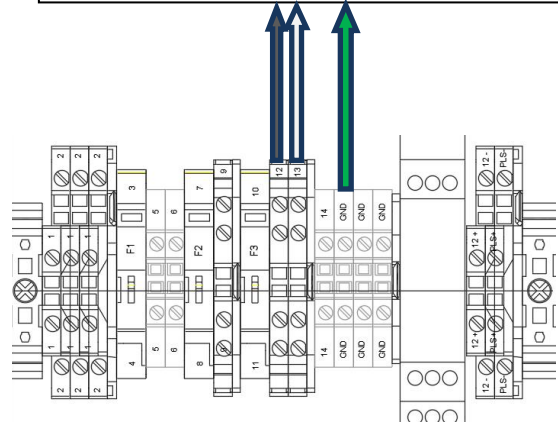

Figure C4: Pump Out Power Terminals.



- 7) If a RFM or additional remote display WILL be used, 12VDC power must be supplied from the remote system. The 12V power is landed on the terminals marked 12V+ and 12V-.

IMPORTANT: Remove batteries from Piusi display for this configuration (see Figs. C6a & C6b).

- 8) The PLS+ and PLS- terminals will supply the pulsed signal from the meter back to the remote system (see Fig.C5).

Figure C6a: Rear lid of Piusi display showing screw locations

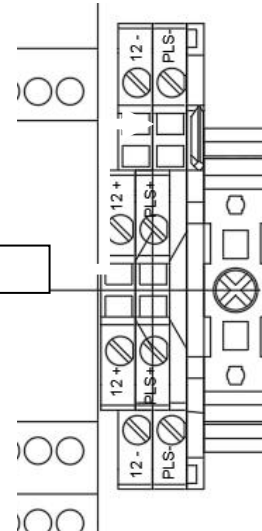

Figure C6b: Batteries in Piusi display w/ pulse out.



NOTE: If NO remote fuel management or remote display will be used, nothing is connected to PLS+, and PLS-.

Figure C5: Pulse-out Meter Connections.



GO TO PAGE 14 OF THIS MANUAL

Model Specific Electrical Installation Instructions

Mini-bulk Tank Mounted Model

SBD KB1062PO & 1062POHR

with *Piusi™ Pulse-out Meter*

KleerBlue™ requires two circuits to power these dispenser models:

- ⇒ One 120 VAC, 20 amp circuit to power the pump.
 - ⇒ One 120VAC, 20 amp circuit to power the dispenser, the tank heaters, and the tank monitor (if present).
 - ⇒ In addition, a 12VDC circuit is required from the Remote Fuel Management (RFM) system (if used)—see item number 7 below.
- 1) The 120VAC, 20 amp pump circuit should come from the RFM system to authorize the dispenser.
 - If the RFM system does not have a 20 amp pump relay, you must purchase a Switch Box (SBD SWBOX-1D) to put between the dispenser and the RFM system. The 120VAC 20 amp power circuit then enters the SWBOX-1D, and is sent to the dispenser when authorized by the RFM.
 - 2) Connect the incoming pump circuit power wires as follows (see Fig. C3, next page):
 - Terminal 9 (Pump 120VAC Line Voltage)
 - Terminal 13 (Pump Neutral)
 - GND (Ground)
 - 3) The second 120VAC, 20 amp circuit will power the heaters in the commercial dispenser. Connect the Heat power wires as follows (see Fig. D4, next page):
 - Terminal 1 (Tank & Disp. Heat, 120VAC Line Voltage)
 - Terminal 2 (Tank & Dispenser Heater Neutral)
 - GRD (Ground)
 - 4) All internal connections from the dispenser to the tank pump, tank heaters, and tank monitor are pre-made at the factory.
 - 5) Terminal 12 is used if a “Motor Running Indicator” is needed.
 - 6) There is a timer that will allow the pump to run for up to 10 minutes. It is adjustable, and resets after the switch is switched to “Off”.
 - 7) If a remote fuel management or remote display WILL be used, 12VDC power must be supplied from the remote system. The 12V power is landed on the terminals marked 12V+ and 12V-. **IMPORTANT: Remove batteries from Piusi display for this configuration** (see Figs. D3a & D3b).

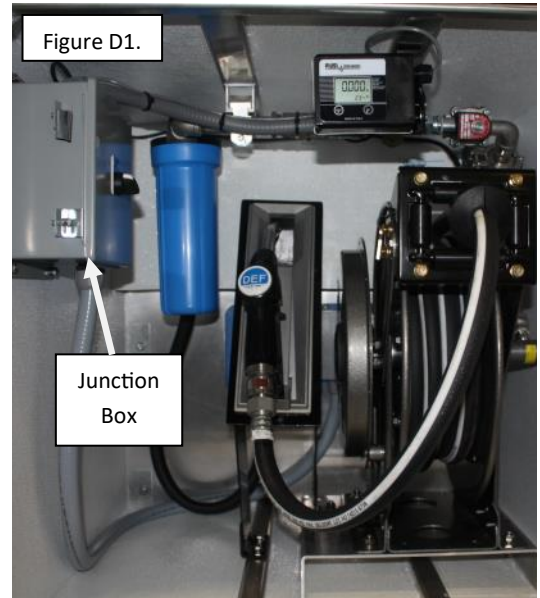
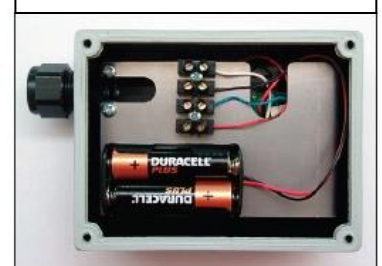

Figure D3a: Rear lid of Piusi display showing screw locations



Figure D3b: Batteries in Piusi display w/ pulse out.



CONTINUED ON NEXT PAGE...

Model Specific Electrical Installation Instructions (cont'd)

Mini-bulk Tank Mounted Model

SBD KB1062PO & 1062POHR

with *Piust*[™] Pulse-out Meter

- 8) The PLS+ and PLS- terminals will supply the pulsed signal from the meter back to the remote system (see Fig.D4).

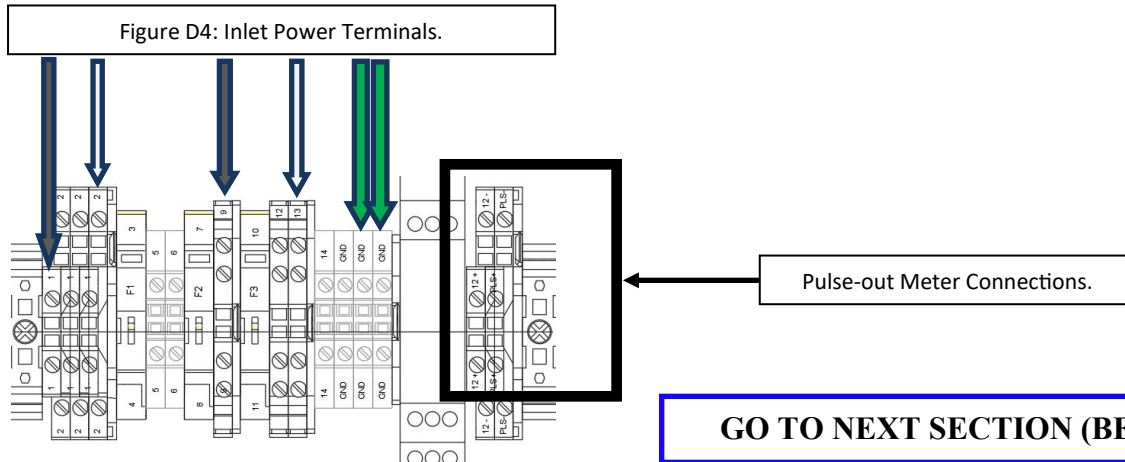

Conclusion of Electrical Installation Instructions - General

- 4) After completing all applicable wiring, seal junction box. Connect power. If Tank Monitor Display is present, it should come on at this time.

Special Note Concerning Use of Multiple Dispensers

- If multiple Dispensers are to be used with a single pump, a switch box is required:
 - ⇒ SBD SWBOX 2D for two (2) dispensers and 1 pump
 - ⇒ SBD SWBOX 3D for three (3) dispensers and 1 pump
 - ⇒ SBD SWBOX 3-6 for up to 6 dispensers and 2 pumps
- When multiple dispensers are being utilized, pump power enters the switch box, and a low-amperage 120V signal will travel from each dispenser to activate the relays located in the switch box.

This concludes the section “Electrical Installation Instructions” of this manual.





System Startup Instructions

It is important to ensure that all dispenser components operate correctly by observing the following procedures when operating the dispenser for the first time:

- Make sure there is DEF in the DEF Storage Tank.
- Activate the pump following the “operating instructions” on the next page. Once primed, you should observe DEF flow of 6-10 gpm.
- If using a nozzle with “mis-fill prevention,” (OPW[®], Husky[®] nozzles) you will need a special magnet on the spout to operate the nozzle.
- The OPW and Husky nozzles are sensitive to air in the system when priming. “Feather” the nozzle handle to bleed all the air out of the system.
- The OPW & Husky nozzles may require the flow to be reduced for proper operation, depending on which pump is used. Restrict the flow by closing the ball valve on the inlet to the dispenser about ½ way. Adjust as needed.
- If the outside temperature is not below 40°F, you may need to place an ice pack on the thermostat to turn the heater on to test its operation. It will take up to 10 minutes for the thermostat to register the cold from the ice pack.
- There will be residue of De-ionized water in the dispenser from testing at the factory. When using for the first time, properly **dispose of the first 2 gallons** (or more if needed) dispensed to ensure the dispenser is purged of DI water.
- The meter in the dispenser is pre-calibrated for DEF at the factory and is ready to use. For more information, see the specific meter Owner’s Manual.

System Operation Instructions

Consult Operating Instructions for your specific dispenser model on the following pages.

Section		MODEL SBD KB1060 & KB1062	16
Section		MODEL SBD KB1060PO & KB1062PO	17
		(Mounted to Mini-bulk Tank)	
Section		MODEL SBD KB1060HR & KB1062HR.....	18
Sec-		tion MODEL SBD KB1060POHR & KB1062POHR.....	19
		(Mounted to Mini-bulk Tank)	

Operating Instructions:



SBD KB1060, SBD KB1062

with *Sotera™ Meter*

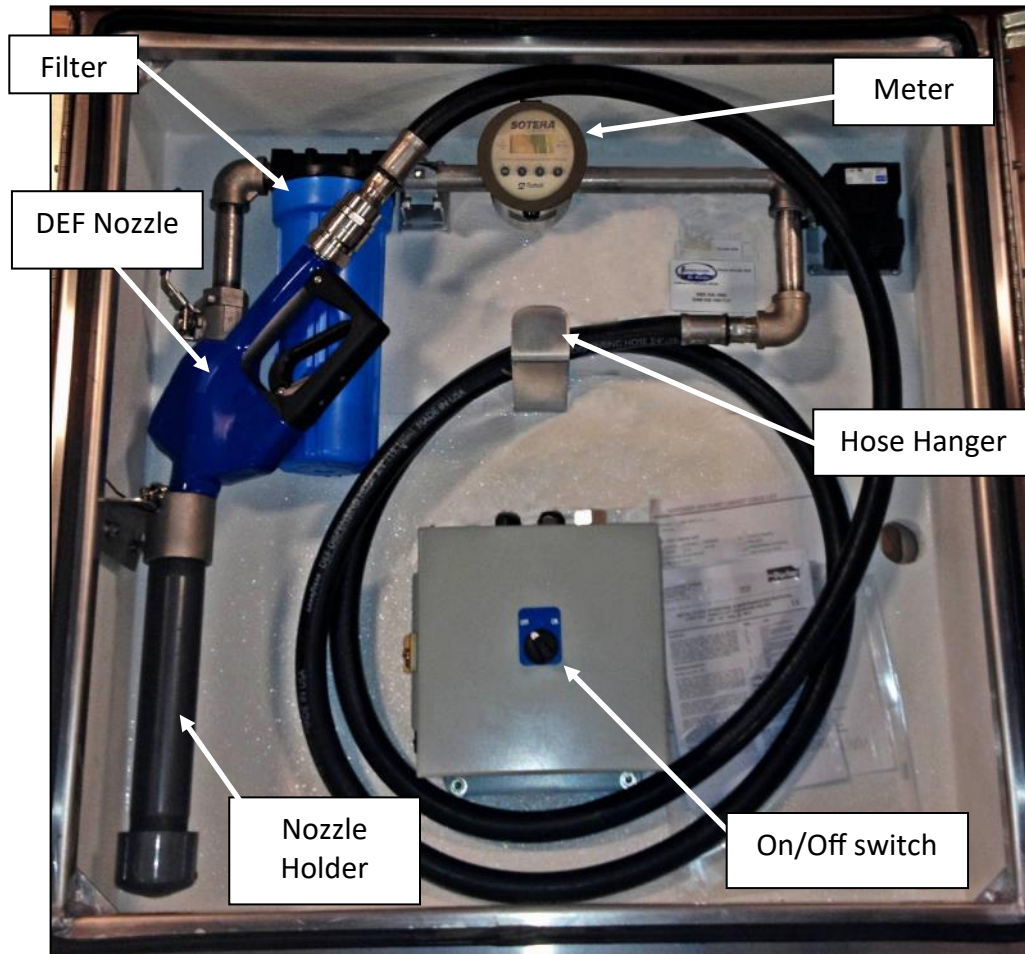

- 1) Ensure that On/Off Switch is in the “OFF” position.
- 2) Turn on meter by pressing the “ON” button.
- 3) Reset meter to 0.00 by pressing and holding “RESET” for 3 seconds.
- 4) Turn On/Off Switch to the ON position.
- 5) Place nozzle in vehicle DEF tank, or an approved container. Vehicle DEF tank generally has a [blue cap](#). DO NOT dispense DEF into the vehicle diesel tank.
- 6) Squeeze nozzle to dispense DEF liquid.
- 7) When dispensing is complete, move switch to the OFF position, and place nozzle into nozzle holder.
- 8) Close and latch cabinet door.
- 9) Meter will power off after 1 minute of non-use.

Operating Instructions:



SBD KB1060PO, SBD KB1062PO

with *Piusi™ Pulse-out Meter*

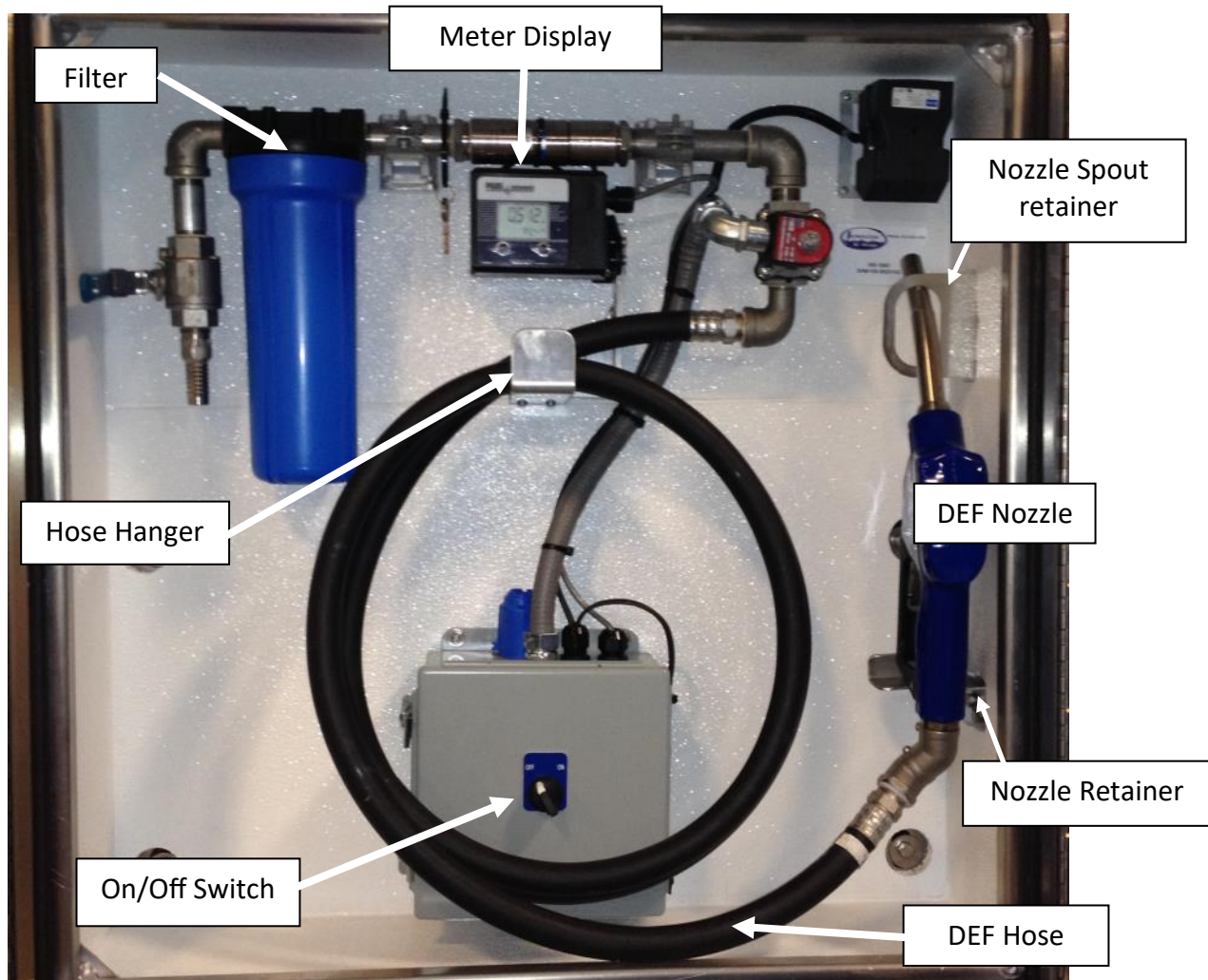

- 1) Ensure that On/Off Switch is in the “OFF” position
- 2) Reset meter to 0.00 by pressing “RESET” on meter display.
- 3) Authorize dispensing unit from the card-lock system (if present).
- 4) When authorized, remove nozzle from cabinet and turn On/Off Switch to the “ON” position.
- 5) Place nozzle in vehicle DEF tank, or an approved container. Vehicle DEF tank generally has a [blue cap](#). DO NOT dispense DEF into the vehicle diesel tank.
- 6) Squeeze nozzle to dispense DEF liquid.
- 7) When dispensing is complete, move switch to the OFF position, and place nozzle into nozzle holder.
- 8) Close and latch cabinet door.

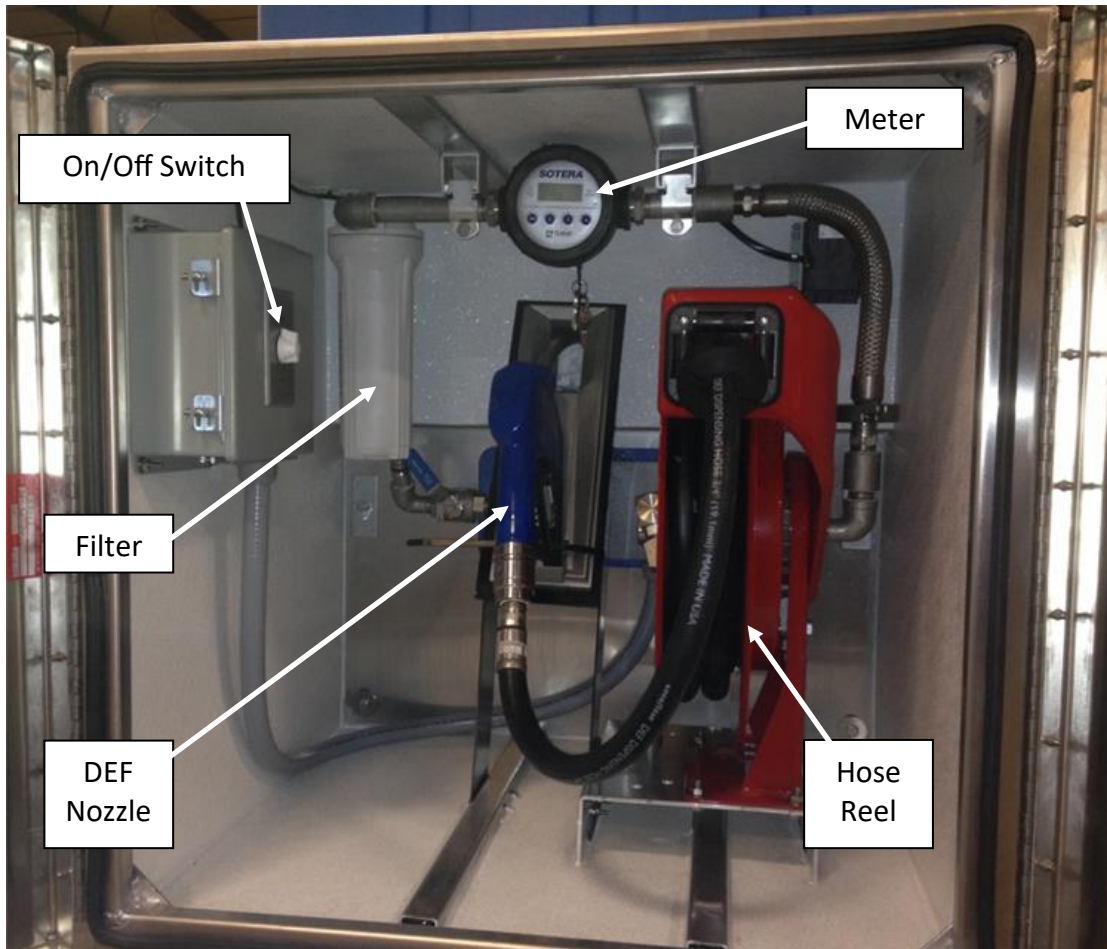
Operating Instructions:**G SBD KB1060HR, SBD KB1062HR***with Sotera™ Meter*

- 1) Ensure that On/Off Switch is in the “OFF” position.
- 2) Turn on meter by pressing the “ON” button.
- 3) Reset meter to 0.00 by pressing and holding “RESET” for 3 seconds.
- 4) Turn On/Off Switch to the ON position.
- 5) Place nozzle in vehicle DEF tank, or an approved container. Vehicle DEF tank generally has a [blue cap](#). DO NOT dispense DEF into the vehicle diesel tank.
- 6) Squeeze nozzle to dispense DEF liquid.
- 7) When dispensing is complete, move switch to the OFF position, and place nozzle into nozzle holder.
- 8) Close and latch cabinet door.
- 9) Meter will power off after 1 minute of non-use.

Operating Instructions



SBD KB1060POHR, SBD KB1062POHR

with *Piusi™ Pulse-out Meter*

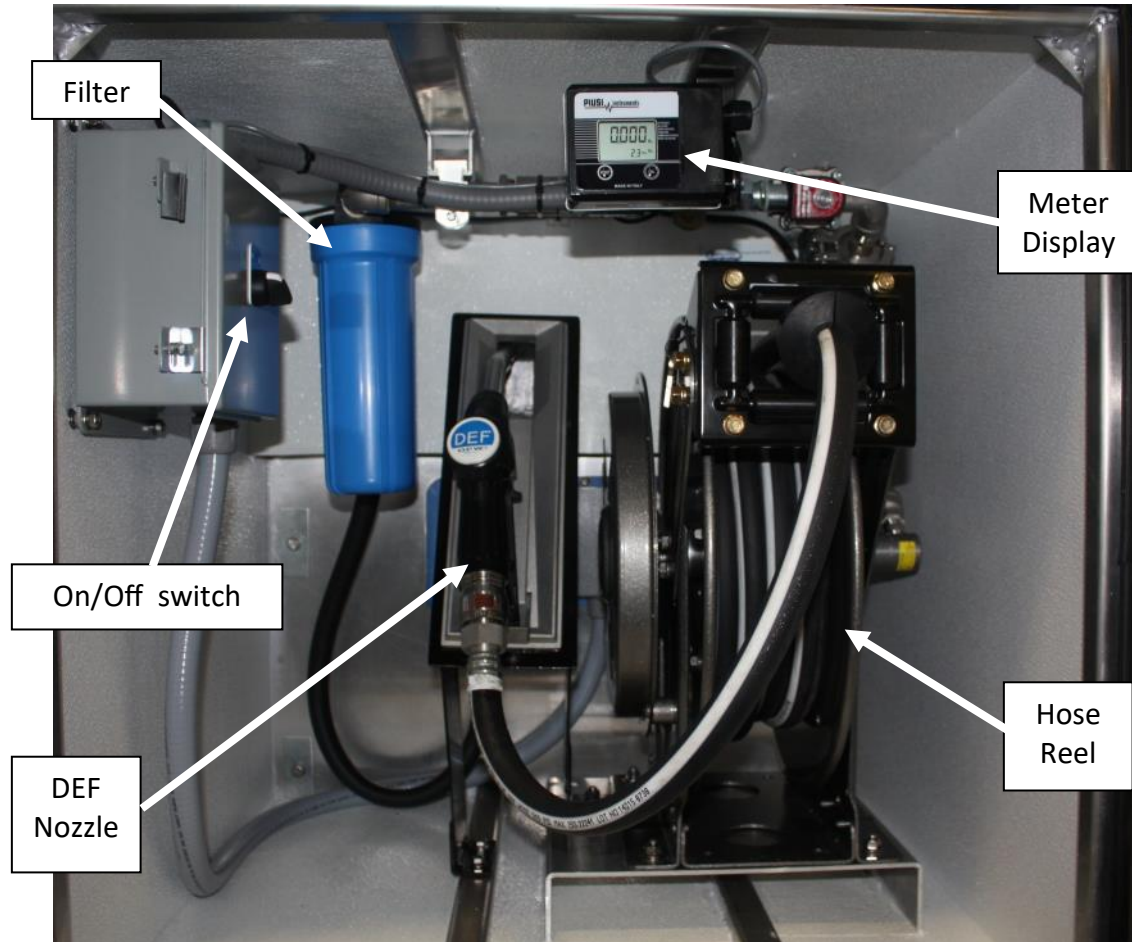

- 1) Ensure that On/Off Switch is in the “OFF” position
- 2) Reset meter to 0.00 by pressing “RESET” on meter display.
- 3) Authorize dispensing unit from the card-lock system (if present).
- 4) When authorized, remove nozzle from cabinet and turn On/Off Switch to the “ON” position.
- 5) Place nozzle in vehicle DEF tank, or an approved container. Vehicle DEF tank generally has a [blue cap](#). DO NOT dispense DEF into the vehicle diesel tank.
- 6) Squeeze nozzle to dispense DEF liquid.
- 7) When dispensing is complete, move switch to the OFF position, and place nozzle into nozzle holder.
- 8) Close and latch cabinet door.

Parts List, KleeBlue™ Commercial Dispensers

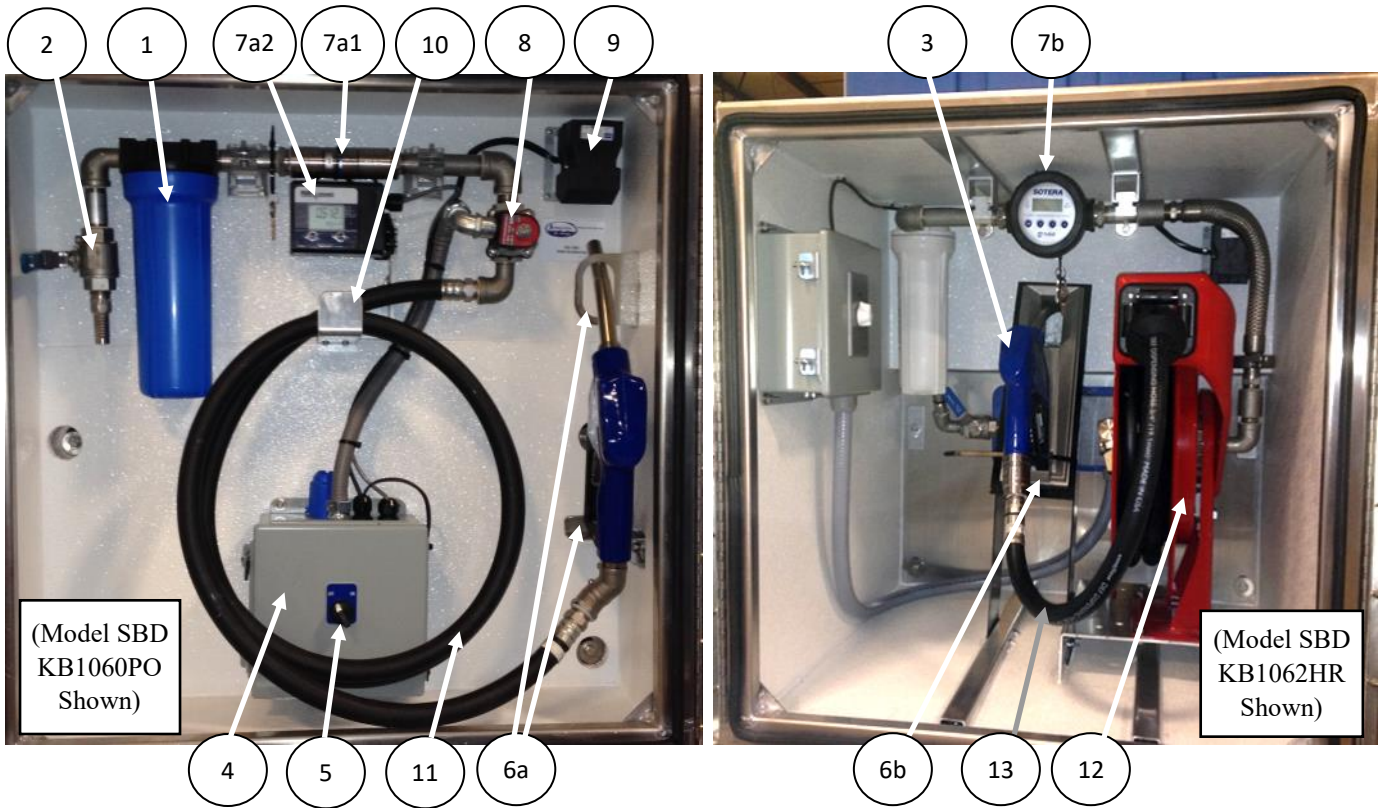

Parts List

Item	Qty	Part #	Description
1	1	SBD POLYFILTER	Filter Cartridge with 1 micron element
2	1	INL 3/4SSLL	Inlet 3/4" Ball Valve, shown with 3/4" hose barb attached
3	Optional	See Options Section	DEF Nozzle (shown with Breakaway), not included
4	1	na	Junction Box Assembly
5	1	AB800 FP-SM22	On/Off Switch
6a	1	SBD 910787 & 910788	Nozzle Retainer Assembly for 10" cabinets
6b	1	SBD 920310	DEF Nozzle Holder Casting Assembly
7a1	1	SBD PI-42000A	Piusi™ Turbine-style Meter
7a2	1	SBD PI-RMTDISP	Piusi™ Display
7b	1	SBD TUT-825	Sotera™ model 825 Meter
8	1	SBD 920125	Solenoid Valve (included in Pulse-Out units only)
9	1	SBD 920300	Heater
10	1	na	Hose Hanger—10" deep cabinet only
11	1	Depends on threads	DEF 12' long dispensing Hose
12	1	SBD 950204	Hose Reel
13	1	Depends on threads	25' long dispensing hose for Hose Reel

Troubleshooting Guide



WARNING ELECTRICAL HAZARD

SERIOUS INJURY OR DEATH MAY RESULT FROM ELECTRICAL SHOCK.

- SHUT OFF ALL POWER SYSTEMS BEFORE PERFORMING MAINTENANCE OR REPAIR
- ONLY CERTIFIED ELECTRICAL CONTRACTORS SHOULD MAKE ELECTRICAL REPAIRS

Problem	Possible Cause	Solution
DEF won't dispense, or flow is slow	Tank is empty	Add DEF to tank.
	Nozzle has mis-fill prevention, requires a magnet to operate	Most truck DEF fill ports have a magnet that activates the mis-fill prevention valve on the nozzle. Not all nozzles have this, but OPW and Husky nozzles do. KlearBlue carries the magnet, and recommends DEF service technicians always carry one with them.
	Pump not getting power.	Power to pump initiates in the dispenser. Check pump power out terminals when switch is on.
	Hose in dispenser is kinked	Check hose and hose reel for proper hose alignment. Replace any worn hose.
	Filter in dispenser is plugged	Replace dispenser filter element.
	DEF Fluid is frozen (weather below 12°F)	Check to see if dispenser and tank heaters are working. Check heat trace and insulation on any exposed piping.
Hose reel becomes locked when the hose is fully extended	Hose reel can "over-travel" if the hose is yanked too hard when fully extended.	<p>Warning: <i>The Hose Reel is under spring tension and can be dangerous! Keep hands and clothing clear of the hose retraction path.</i></p> <p>CAREFULLY rotate hose reel counter-clockwise about 1/4 turn, then gently allow the hose reel to retract the hose.</p>

Maintenance and Repair

 **WARNING**
ELECTRICAL HAZARD

SERIOUS INJURY OR DEATH MAY RESULT FROM ELECTRICAL SHOCK. SHUT OFF ALL POWER TO SYSTEM BEFORE PERFORMING MAINTENANCE OR REPAIR.



 **WARNING**
PRESSURIZED FLUID HAZARD

SERIOUS INJURY OR DEATH MAY RESULT FROM PRESSURE IN SYSTEM. RELIEVE SYSTEM PRESSURE TO ZERO BEFORE PERFORMING MAINTENANCE OR REPAIR.



CAUTION

Maintenance and repair should be performed by a licensed electrician or certified contractor.

I. General:

- 1) Wipe up any spilled DEF that might be inside the cabinet. DEF fumes can be hard on the electrical equipment over time.
- 2) **DO NOT** power-wash the dispenser. Wipe with a clean, soft cloth using mild soap.
- 3) **Thread Sealant:** Threaded connections should be made as follows:
 - Coat the male thread with Loctite® 7649 Activator/primer. Allow to dry for 2 minutes.
 - Apply a liberal amount of Loctite® 567 Thread Sealant to the male thread only. Assemble the threaded components, and tighten well.
 - Allow to cure for at least 6 hours before running DEF through the connection.

II. Filter: The 1-micron ultra-efficient filter element provides premium filtering of DEF to protect your SCR equipment. KlearBlue recommends changing the element yearly, or when your dispenser flow rate is significantly reduced and cannot be attributed to other reasons. **SBD 1MICRON** is the part number for the 1-micron replacement element.

- 1) Shut off power to the system, and close the 3/4" inlet valve in the dispenser. *Note the position of the valve handle if it has been used to slow the flow to the DEF nozzle.*
- 2) Bleed all pressure out of the system by opening the DEF nozzle and draining it into an approved container. *Note that nozzles with mis-fill prevention devices (OPW) require a magnet to open.*
- 3) Place a drip basin below the filter housing, then slowly twist the housing cylinder counter-clockwise to loosen. *Note there may still be some pressure in the system.*
- 4) Dump any fluid in the filter cylinder into an approved container. Dispose of the old element.
- 5) Install a new filter element into the cylinder. Make sure the o-ring that seals the cylinder to the filter housing is in place.
- 6) Thread the cylinder clockwise onto the filter housing. Tighten by hand until snug. Do NOT over tighten.

III. Hose: The hose in the dispenser will wear over time, especially where it connects to the nozzle. Periodically inspect for cracks and tears, and replace damaged hose. Use only KlearBlue DEF hose. When ordering replacement hose, you need to know what threads are on the nozzle end.

IV. Nozzle: Over time, the DEF nozzle may wear or become damaged. Faulty nozzles should be replaced. New nozzles can be ordered from KlearBlue. Be sure to order the nozzle with the correct threads.

V. Before Cold Weather begins:

- 1) **Inspect door seal integrity.** Damaged seals should be replaced.
- 2) **Inspect cabinet heater.**
 - Clean off any dust accumulation using a vacuum.
 - Put an ice pack on the thermostat for 10 minutes to make sure the heater will turn on.

KleerBlue™ Solutions **Exclusive Limited Warranty**

Subject to the terms and limitations set forth in this limited warranty (“Warranty”), KleerBlue Solutions (“KleerBlue”) warrants to the original purchaser (“Purchaser”) of the **KleerBlue Commercial Dispenser** (“Equipment”), to be free, under normal use and service, from defects in materials and workmanship **for a period of one (1) year** from date of original invoice. KleerBlue’s entire liability under this Warranty is limited to either repairing or replacing, at KleerBlue’s option; provided that Equipment is returned to KleerBlue transportation charges prepaid, and that upon KleerBlue’s examination, Equipment or workmanship is determined to have been defective upon delivery to the Purchaser.

For this Limited Warranty to take effect, Purchaser must submit completed DEF Installation Checklist, supplied in the equipment Installation and Operating Manual, to KleerBlue Solutions, at the email or street address noted below.

Claim Procedures

In order to obtain performance by KleerBlue of its obligations under this warranty, the Purchaser must first contact KleerBlue Solutions in order to report the problem. **Only KleerBlue Solutions Customer Service can approve or authorize warranty claims.** Purchaser must supply the following information:

1. Contact name, address, and telephone number for site where KleerBlue equipment is located
2. Original invoice or model and serial number of the Product
3. A description of the problem and how it occurred.

If the Equipment is to be returned to KleerBlue, a **Return Goods Authorization Number** (“RGA Number”) must be created by a KleerBlue customer service representative prior to return shipment. KleerBlue reserves the right to request photos of the defect before authorizing return or repair.

Limitations

There are no other warranties of any kind expressed or implied. KleerBlue specifically disclaims any warrant of merchantability or of fitness for any particular purpose. KleerBlue’s sole obligation, which shall represent the buyer’s sole and exclusive remedy, shall be to repair or at KleerBlue’s option to replace any product or part determined to be defective. In no event shall KleerBlue be held liable for any special, direct, indirect, incidental, consequential or other damages of similar nature incurred, nor any liability to be assumed except as expressly provided herein; there is no other express or implied warranty.

Exclusions

Neither labor nor travel costs which may be incurred to repair or replace defective parts or equipment are covered under this warranty. This Warranty does not cover any products not manufactured by KleerBlue; such items are subject to warranties provided by their respective manufacturers. This warranty does not extend to any equipment which has been subjected to improper installation, misuse, negligence, or accident, or if installed and/or operated in any manner other than in accordance with KleerBlue’s **Installation and Operating Instructions**, nor does it extend to any equipment which has been modified in any way without express authorization from KleerBlue Solutions. This warranty applies only to KleerBlue products sold in the United States and Canada.

Design and Equipment

Any changes in design or improvements added shall not create any obligation to install same on equipment previously sold or ordered.

Returning Equipment to KleerBlue

Equipment returned to KleerBlue must be clearly labeled with a RGA Number prior to return shipment. Equipment returned to KleerBlue without a RGA Number will not be processed. All Equipment to be returned must be shipped freight prepaid by the Purchaser to KleerBlue to the location specified by the KleerBlue customer service representative.

E-mail DEF Installation Check lists to: sales@kleerbluesolutions.com, or
Mail DEF Installation Check Lists to: KleerBlue Solutions, 2515 Charleston Place, Fort Wayne, IN 46808

KLEERBLUE SOLUTIONS : (800) 320-2122 : service@kleerbluesolutions.com

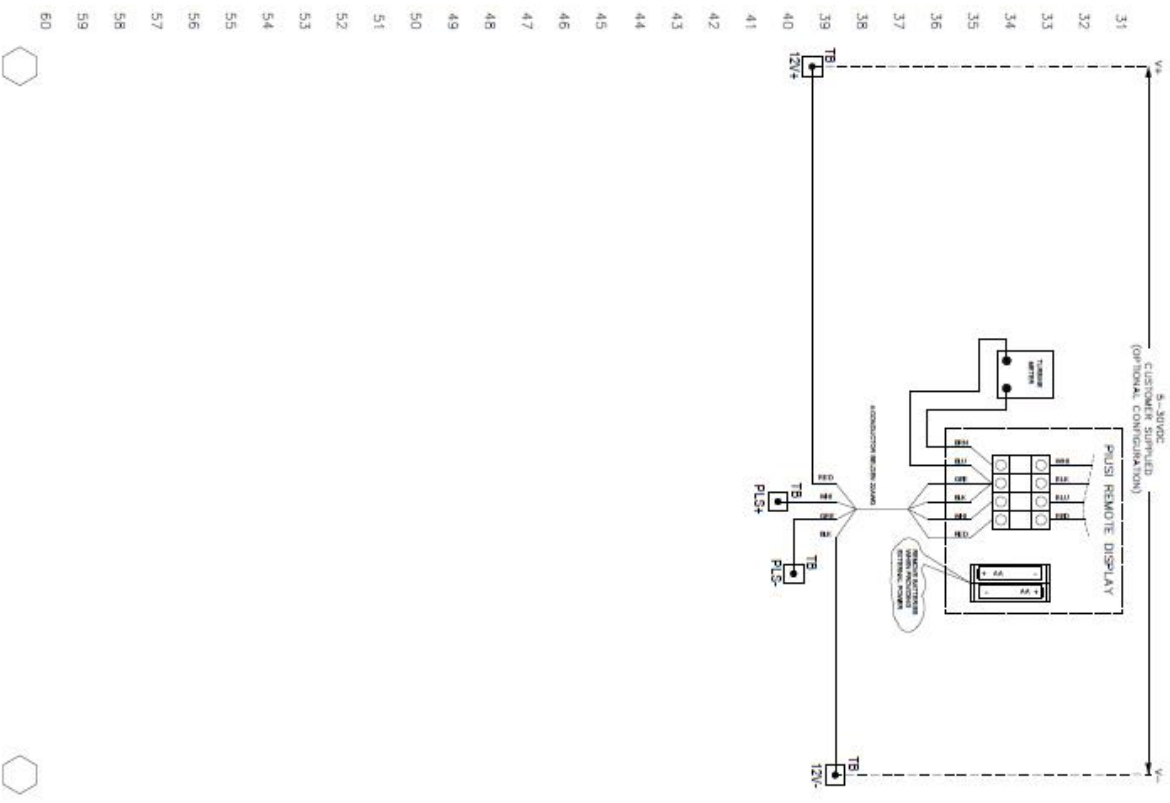
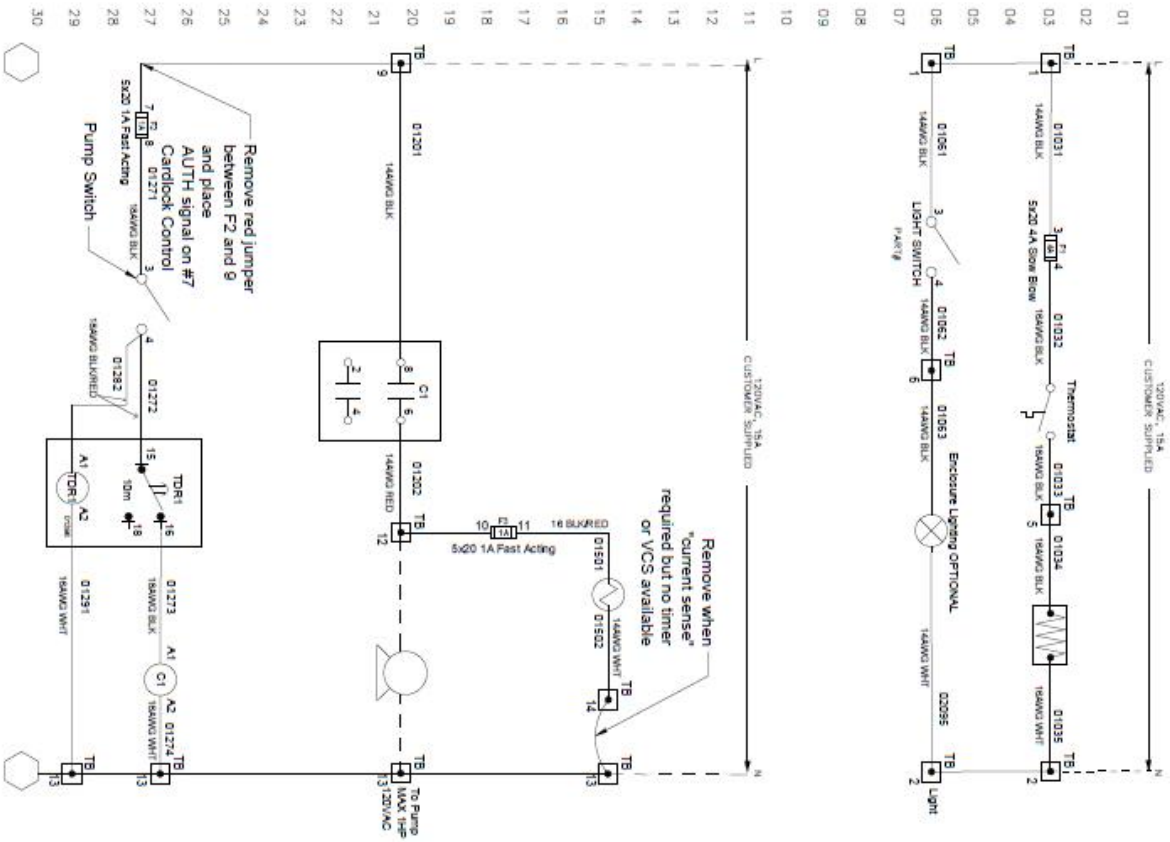

DEF Dispenser Installation Checklist

Dispenser SN:	Installation Co:
Customer:	Technician:
Site Address:	Date:

Refer to the KleeBlue Dispenser Installation & Operating Manual (OM) for details

- REVIEW** KleeBlue DISPENSER INSTALLATION & OPERATION MANUAL (OM).
- PERMITS:** Obtain all local and state permits as required.
- Inspect DISPENSER:** inspect for dents and scratches before signing shipping receipt. Notify delivery company of any observed damage, and refuse acceptance of shipment if damage is present.
- SET DISPENSER:** Carefully unload unit with a forklift, picking up from the bottom of dispenser, and set into place on concrete pad.
- ANCHOR DISPENSER:** Using concrete anchors, anchor the dispenser to the concrete surface being used.
- POWER:** Install all required electrical power with emergency shutoff and sign per code if required. Conduits should be installed according to national and local codes. All penetrations into the dispenser must be sealed with sealing type conduit fittings to protect the dispenser interior from weather. Do not install conduit through the top of the dispenser; rather, route through the dispenser bottom or side.
- EXTERNAL PIPING:** DEF must be kept PURE! See the OM for acceptable materials.
- DISPENSER STARTUP** (see operation manual):
 - ◇ Fill the DEF storage tank with DEF.
 - ◇ Authorize the dispenser and dispense DEF into container. Initial 2 gallons of product dispensed must be disposed of.
 - ◇ Note that some nozzles require a magnetic interlock before they will dispense. The magnet is found in the DEF Tank Fill Port on the diesel vehicle. Magnets for testing can be ordered from KleeBlue, part # SBD OPWMFPD.
 - ◇ For retail dispensers, bleed the air out of the top of the TCS 682 meter.
- CLEAN UP:** Clean up all debris. Sweep entire installation area.
- Photos:** Take digital photos of completed project. Submit photos with signed installation checklist. (Photos required from all four sides/angles, after all debris has been removed).
- Training:** Local Service Manager must be trained on the functionality of the system. Signature from the installer and the representative is required for warranty to be valid. Provide all keys to Service Manager

CONTRACTOR: _____ DATE: ____ / ____ / ____

CUSTOMER: _____ DATE: ____ / ____ / ____

THIS COMPLETED FORM & PHOTOS MUST BE SUBMITTED TO REGISTER EQUIPMENT FOR WARRANTY.

SUBMIT TO:

sales@kleebluesolutions.com

-or-

KleeBlue Solutions

2515 Charleston Place, Fort Wayne, IN 46808 • (800) 320-2122 •



KleerBlue Solutions

Evansville, Indiana

Fort Wayne, Indiana

Phone (800)320-2122

www.kleerbluesolutions.com